

RAAF

F/A-18 FLIGHTLINE COMMUNICATIONS HEADSET



NSN: 5965-66-151-5433

Cage Code: Z8X88

***HEADSET INSTRUCTIONS
AND
USER GUIDE***

INDEX

CERTIFICATION DATA	2	PARTS REPLACEMENT	8 - 9
WARNINGS	2	NOISE EXPOSURES	10
FITTING INSTRUCTIONS	3 - 7	WARRANTY	11
CARE & MAINTENANCE	7	CONTACT DETAILS	12

CERTIFICATION DATA

Mobile One headsets are tested and comply with AS/NZS1270 -2002, Acoustics - Hearing Protectors. NOTE: As hearing protectors, Headsets must be selected, used and maintained according to AS/NZS 1269.

These instructions must be followed if the headset is expected to perform as indicated by the SLC80 rating in the chart below:

MODEL No.	SLC80 RATING	CLAMP FORCE	MASS	FREQUENCY Hz	125	250	500	1000	2000	4000	8000
HMP-1	30	10.0	455	MEAN	15.5	19.7	29.7	34.7	35.1	39.6	39.3
				STD. DEVTN.	3.5	2.7	4.0	3.2	3.5	4.5	6.0
				MEAN – STD. DEV.	12.0	17.0	25.7	31.5	31.6	35.1	33.3

Class Determination as per AS/NZS1270- 2002:	
HMP-1	Class 5

WARNINGS

This headset will only provide the hearing protection as indicated by the SLC80 rating when it is maintained in good working order and fitted correctly. Other factors affecting the noise attenuation characteristics of the headset are items which affect the seal between the Ear Cushion and the head e.g. thick framed glasses, protective clothing such as balaclavas, thick beards, etc.

It is vitally important that you give consideration to the sound output produced by the earphones in the headset itself. You must ensure that the volume setting of the radio, or other connected device, is adjusted to a safe listening level as there are no output limiting devices included within the electronic circuitry of the headset.

For correct care of this Headset, you must refer to the Care and Maintenance Instructions on page 7.

FITTING INSTRUCTIONS

The purpose of a Headset is to:

- 1. Protect your hearing**
- 2. Provide electronic communications**

Correct fitment of the Headset to your head is vital for maximum hearing protection and to optimise communications ability.

A CORRECTLY FITTED HEADSET

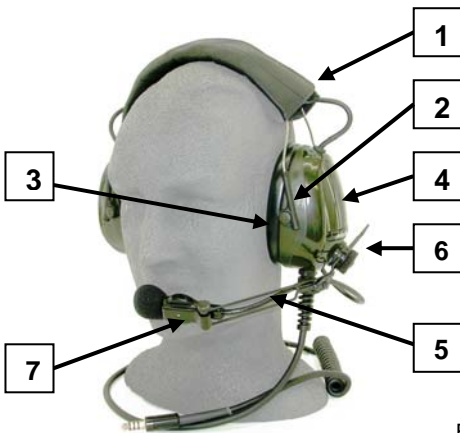

Figure A



Figure B

PARTS OF A HEADSET



- 1. Headband**
- 2. Adjusting Slide**
- 3. Ear Cushion**
- 4. Ear Cup**
- 5. Mic. Boom**
- 6. Mic. Boom Clamping Nut**
- 7. Microphone Element**

Figure C.

NB: The Headset Ear Cups must be fitted over your ears covering and enclosing them completely

The Headset should be fitted so that the horizontal axis of the Ear Cup bisects the approximate tip of the nose of the wearer. This usually means the Headband of the headset will be located directly above the ears, however the headband may be adjusted slightly forward or rearwards for maximum comfort. See figure D below.

Note:

- 1. The horizontal axis at the nose is shown as the solid white line**
- 2. The vertical position of the Headband on the top of the head as compared the vertical white dotted line**

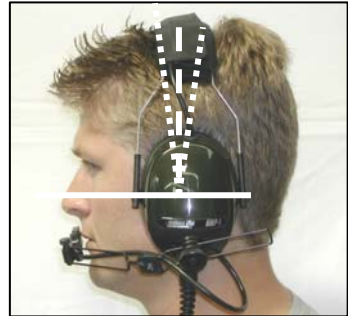

Figure D

STEP BY STEP USER GUIDE

NOTE: The Headset is intended to be worn with the microphone and cable on the left side of the head.

STEP 1 Adjusting position of the Mic. Boom

Release the holding tension of the Microphone Boom (Figure C, item 5) by unscrewing clamping nut (Figure C, item 6) counter clockwise just enough to be able to move the boom. This usually takes less than a one quarter turn. You will see that the boom can rotate up or down to select the best positioning angle. It can also slide in or out to select the correct length for your head size. Retighten nut after adjustments (see figure 1.1, right)

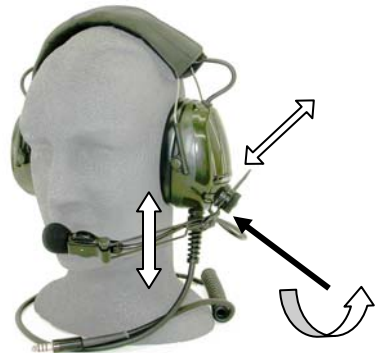

Figure 1.1

The Microphone Boom can be further adjusted so that the Microphone element (Figure C, item 7) can be correctly positioned in the centre of the mouth opening. Move the ball joint at the mid point of the Microphone Boom to shape the Boom as required. Also, the screw at the Microphone element can be loosened by half a turn counter clockwise to adjust it's angle. Finger-tighten screw after adjustments. (see Figure 1.2, right)

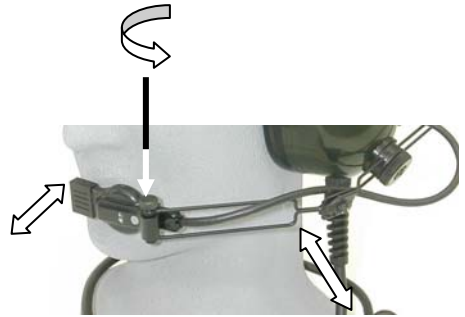

Figure 1.2

STEP 2 Fitting the Headset

Holding the Ear Cups as shown, slightly stretch Headset apart just enough to place over your head (see Figure 2.0). Release and make sure the Ear Cups sit evenly over your ears and cover them completely. Move the Headset so the Headband is sitting correctly and comfortably on your head (see again Figure D).



Figure 2.0

NB: Do not over-stretch headset

STEP 3 Adjusting the Ear Cups

a) Figure 3.1 below illustrates how the black Adjusting Slides can be moved up or down on the Headband. This allows you to adjust the position of the Ear Cup to provide better comfort and a more efficient seal on the head to keep out noise.

b) With one hand, hold the Headband steady at the top of your head (as shown in Figure 3.2). Holding the Ear Cup with your other hand, move it up or down to find the best position so that the Ear Cup completely seals onto your head, around your ear. No part of the ear should be caught between the Ear Cushion and the head. Make similar adjustments for both sides and ensure Headset fits snugly.

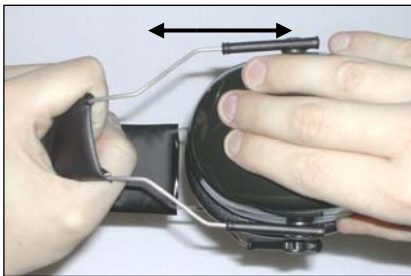

Figure 3.1



Figure 3.2

STEP 4 Ensuring Ear Cups seal against your head



Placing one hand against each Ear Cup, firmly push both Ear Cups inwards against your head and hold for 2 seconds. This action moulds and helps the Ear Cushions to form an efficient seal against the head around your ears improving both comfort and hearing protection.

Figure 4.0

STEP 5 Adjusting the Mic. for maximum clarity

(5a) ADJUSTING MIC. DISTANCE

Microphone must be positioned as close to the lips as is comfortable. This provides better voice clarity See Figure 5.1.

**Maximum Distance
From lips = 5 mm**



Figure 5.1

(5b) ADJUSTING MIC. POSITION

Adjust windsock (Microphone) to be directly in the centre of the mouth opening. See figure 5.2.

NB: Project your voice loudly and clearly into the microphone



Figure 5.2

STEP 6 Checking electronic operation

Check Earphones (speakers)

You should hear sound from your radio in both Ear Cups. If this is not the case, check the connection to the communications device or that the device is operating properly

Check Microphone

Check that the speech you are attempting to transmit is reaching the intended person, clearly.

Caution: Do not set the volume level of the radio, or other connected, device too high! See paragraph 2, **Warnings** on page 2.

CARE & MAINTENANCE

We recommend that your headset be cleaned regularly, by wiping with a damp sponge containing mild soap and water. Pay special attention to the Ear Cushions to ensure removal of perspiration and skin oils which can reduce the service life of the Cushions. These areas of the Headset that come into contact with the wearer's skin should also be regularly disinfected using isopropyl alcohol wipes.

When cleaning **DO NOT** allow moisture to enter the Ear Cup assemblies or any part of the Microphone Assembly. **UNDER NO CIRCUMSTANCES SHOULD YOU IMMERSE THE HEADSET IN ANY LIQUID.**

To maintain the noise attenuation properties of the Headset, the Ear Cushions (see Figure 6.0, item 2) should be replaced every six months and the inner foam assembly (see Figure 6.0, item 3) every twelve months. More frequent replacement of these items may be required if the Headset is being used under extreme conditions. Inspect the headset regularly for signs of damage or wear.

IMPORTANT: This Headset should not be stored or stowed in direct sunlight or temperatures above 55 degrees C. as distortion of the Ear Cushions may occur.

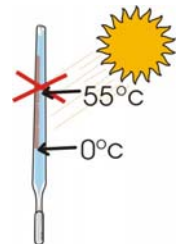

PARTS REPLACEMENT (See items 1 – 4 pictured in Figure 6.0)

The LEATHER HEAD BAND COVER (item 1) is simply wrapped around the Head Band with the edges overlapping so that the Velcro seam can be evenly pressed together. To remove the cover, pull the top overlap away from the bottom at the Velcro seam.

The EAR CUSHIONS (item 2) are removed by placing one or two fingers inside the Ear Cup and under the Ear Cushion's rigid plastic plate. Hold the Ear Cup firmly with the other hand and pull the Ear Cushion plate until it pops out of the Cup. The new Cushions just clip back into place under the lip around the circumference of the ear Cup opening. Ensure the Ear Cushion plate has seated and clipped-in properly before use.

The INNER FOAM ASSEMBLY (item 3) also supports the Earphone and care should be taken not to damage the wiring. With the Ear Cushions removed, carefully take out the foam wafer and pull apart the two bottom layers where the wires enter. Carefully remove the Earphone. Place the Earphone into the new foam, remove paper cover and press both layers together. Install foam back in cup and replace Ear Cushion.

The WIND SOCK (item 4) is the black foam cover for the Microphone at the end of the Mic. Boom. To remove, simply pull the Wind Sock off the end of the Microphone and gently stretch and pull the replacement Wind Sock over the Microphone again.

HEADSET PARTS – EXPLODED VIEW

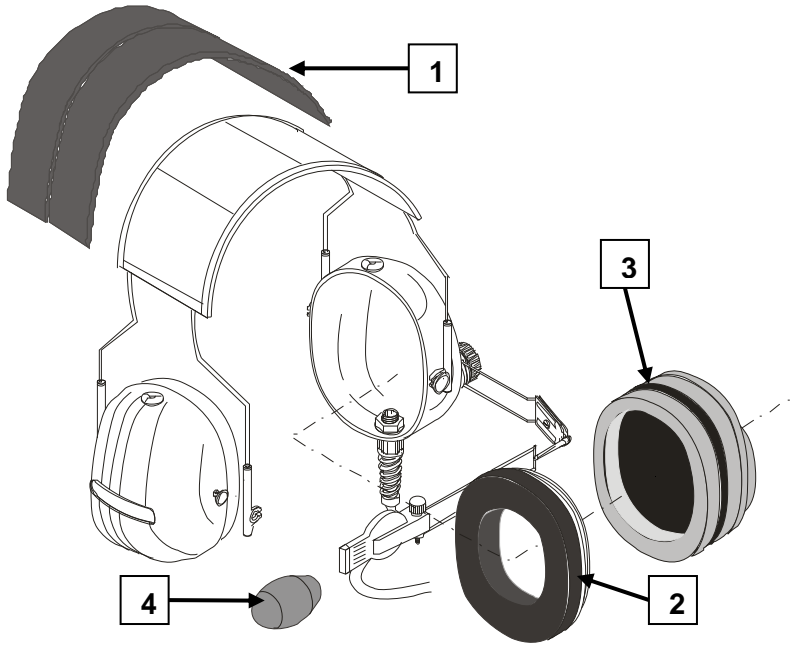

Figure 6.0

REPLACEMENT PARTS LIST

Item No:	Order Code	Description
	NSN:	
1	7432300147	Leather Headband Cover (item 1)
2	7432300178-K	Cushion Kit (Pack of 2 x item 2)
	5965-66-151-5602	
3	7432300174-K	Foam & Cushion Kit (Pack of 2 x items 2 & 3)
	5965-66-151-5603	
4	7432300179	Windsock for Microphone (Pack of 1 x item 4)

NOISE EXPOSURES

There is considerable medical research data now available which clearly demonstrates a link between the loss of hearing in humans as a result of exposure to noise. The factors which contribute to this loss of hearing are many and complex, and as the Headset user you should discuss your requirements with suitably qualified professionals to ensure that the headset you have selected is suitable for the type (frequencies) of noise & level of noise you may encounter as well as the period of exposure. The chart below should be read in conjunction with AS/NZ standard 1269.

Noise Exposure Chart

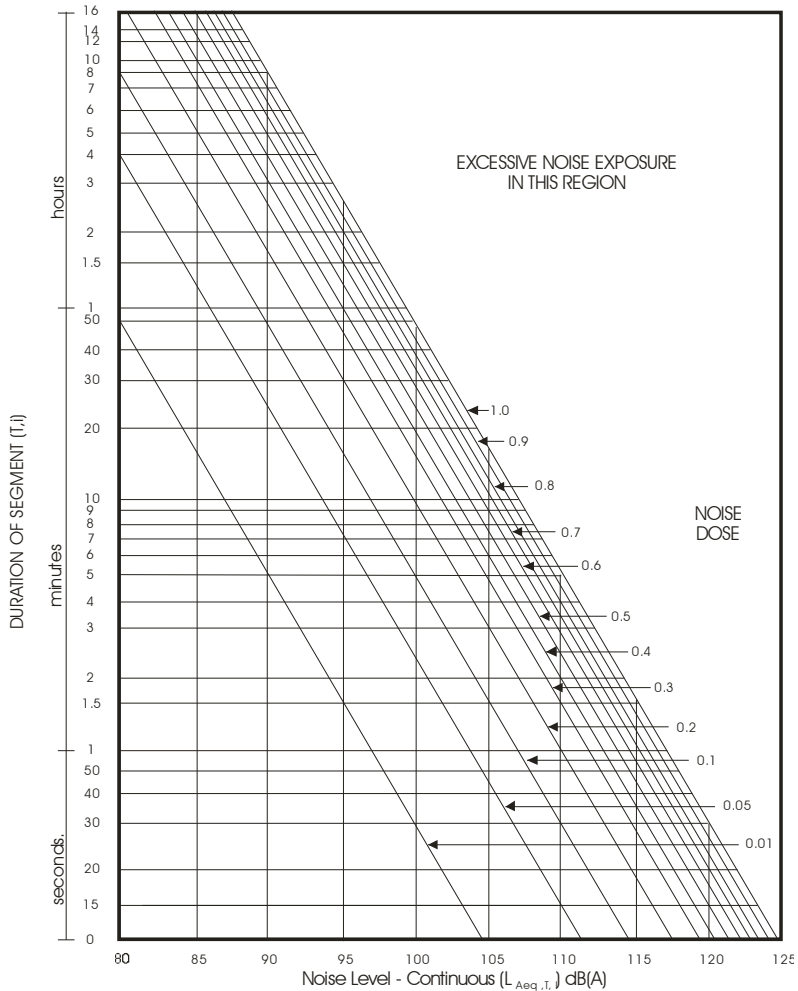

WARRANTY

WARRANTY STATEMENT

Our goods come with guarantees that cannot be excluded under the Australian Consumer Law. You are entitled to a replacement or refund for a major failure and for compensation for any other reasonably foreseeable loss or damage. You are also entitled to have the goods repaired or replaced if the goods fail to be of acceptable quality and the failure does not amount to a major failure.

This warranty is given by Mobile One Australia Pty Limited, ABN 44 001 885 696, Camden Airport Camden NSW 2570 Ph 02 4655 6677

The benefits conferred by this warranty are in addition to all other rights and remedies in respect of the product (or service) which the consumer has under the Australian Consumer Law and any other law in relation to goods and services to which this warranty relates.

Any Mobile One Australia Pty Limited product that fails due to manufacturing defects will be repaired or replaced as follows:

General Aviation & Helicopter Headsets

Three (3) full years from date of purchase

Intercoms, Headsets other than above & Accessories

One (1) full year from date of purchase

Base, Mobile Antennas & Accessories

Five (5) full years from date of purchase

What this warranty does not cover

All headset inner foam assemblies windsocks & ear pads.

Goods that have been modified or altered in any way.

Defects or damage resulting from misuse, accident, impact or neglect.

Goods improperly installed or used contrary to the relevant user guide.

Unauthorised service and or repairs.

How to make a warranty claim

Before the end of the applicable warranty period (see above) return the goods at your expense together with details of the defect, proof of purchase and your contact details.

Subject to accepting your claim, we will return your repaired or replacement product back to you by the best shipping method at our cost.



Mobile One Australia Pty Limited
Camden Airport Camden NSW 2570
PO Box 123 Camden NSW 2570
Ph 02 46556677 Fax 02 46556600
support@mobileone.com.au

M1Warranty 2012 rev1

CONTACT DETAILS

**Mobile One Australia Pty Limited
Electro-Acoustic Service Centre
Camden Airport, Camden NSW.**

**P.O Box 123
Camden
NSW 2570**

**AUSTRALIA
Phone 02 4655 6677
Fax 02 4655 6600**

**INTERNATIONAL
Phone 61 2 4655 6677
Fax 61 2 4655 6600**

www.mobileone.com.au

