

RAAF

**F-111
FLIGHTLINE
COMMUNICATIONS
HEADSET**
with MOUTH GUARD MICROPHONE



NSN: 5965-66-153-5381

HNP-1-MGM (5/19)

CAGE: Z8X88

***HEADSET INSTRUCTIONS
AND
USER GUIDE***

INDEX

CERTIFICATION DATA	2	PARTS REPLACEMENT	8 - 9
WARNINGS	2	NOISE EXPOSURE	10
FITTING INSTRUCTIONS	3	WARRANTY	11
HEADSET	3 - 6	CONTACT DETAILS	12
CARE & MAINTENANCE	7		

CERTIFICATION DATA

Mobile One headsets are tested and comply with AS/NZS 1270 - 2002, Acoustics - Hearing Protectors. NOTE: The headsets must be selected, used and maintained according to AS/NZS 1269.

These instructions must be followed if the headset is expected to perform as indicated by the SLC80 rating in the chart below:

PRODUCT CODE	SLC80 RATING	CLAMP FORCE	FREQUENCY Hz	125	250	500	1000	2000	4000	8000
HNP-1	30	10.8	MEAN	16.0	19.5	29.5	33.4	34.4	39.9	42.1
			STD. DEVTN.	3.3	3.1	2.6	3.3	3.6	2.3	5.8
			MEAN – STD. DEV.	12.7	16.4	26.9	30.1	30.8	37.6	36.3

Class Determination as per AS/NZS1270- 2002:	
HNP-1	Class 5

Total Headset Weight = 384 gms

WARNINGS

This headset will only provide the hearing protection as indicated by the SLC80 rating when it is maintained in good working order and fitted correctly. Other factors affecting the noise attenuation characteristics of the headset are items which affect the seal between the Ear Cushion and the head e.g. thick framed glasses, protective clothing such as balaclavas, thick beards, etc.

It is vitally important that you give consideration to the sound output produced by the earphones in the headset. You must ensure that the volume settings of the aircraft intercom system are adjusted to a safe listening level as there are no output limiting devices included within the circuitry of the headset.

For correct care of this Headset, you must refer to the Care and Maintenance Instructions on page 7.

FITTING INSTRUCTIONS - HEADSET

The purpose of a Headset is to:

1. **Protect your hearing**
2. **Provide electronic communications**

Correct fitment of the Headset to your head is vital for maximum hearing protection and to optimise communications ability.

A CORRECTLY FITTED HEADSET



Figure A



Figure B

PARTS OF HEADSET

1. Headband
2. Adjusting Slide
3. Ear Cushion
4. Ear Cup
5. Mouth Guard Microphone
6. MGM Lanyard Strap
7. MGM Mouth Pad
8. MGM Headset/ Interconnect
9. PTS Push to Speak Button

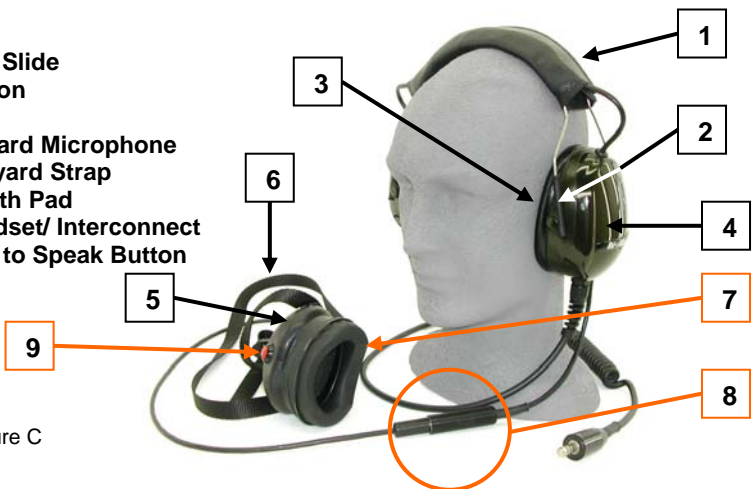

Figure C

FITMENT INSTRUCTIONS (CONTINUED)

NB: The Headset Ear Cups must be fitted over your ears covering and enclosing them completely

The Ear Cups should also be fitted so that the axis of the Ear Cup bisects the approximate tip of the nose of the wearer. This usually means the Headband of the earmuff will be located slightly in front of the top – centre of your head. The Headset will also be angled forward a little. See figure D below.

Note:

- 1. The horizontal axis at the nose shown as the solid black line**
- 2. The slight forward position of the Headband on the top of the head as compared the vertical white dotted line**

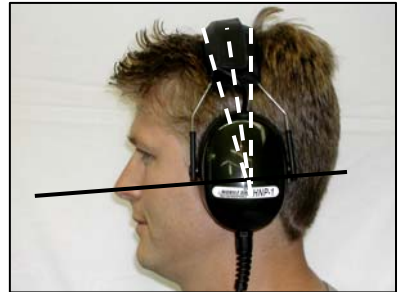

Figure D

STEP BY STEP USER GUIDE

STEP 1 Fitting the Headset

Holding the Ear Cups as shown, slightly stretch Headset apart just enough to place over your head (see Figure 1.0). Release and make sure the Ear Cups sit evenly over your ears and cover them completely. Move the Headset so the headband is sitting correctly and comfortably on your head (see again figure D).

NB: Do not over-stretch headband



Figure 1.0

STEP 2 Adjusting the Ear Cups

a) Figure 2.1 below illustrates how the black Adjusting Slides can be moved up or down on the Headband. This allows you to adjust the position of the Ear Cup to provide better comfort and a more efficient seal on the head to keep out noise.

b) With one hand, hold the Headband steady at the top of your head (as shown in Figure 2.2). Holding the Ear Cup with your other hand, move it up or down to find the best position so that the Ear Cup completely seals onto your head, around your ear. No part of the ear should be caught between the Ear Cushion and the head. Make similar adjustments for both sides and ensure Headset fits snugly.

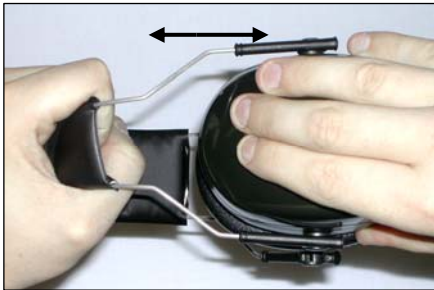

Figure 2.1



Figure 2.2

STEP 3 Ensuring Ear Cups seal against your head



Figure 3.0

Placing one hand on each Ear Cup, firmly push both Ear Cups inwards against your head and hold for 2 seconds. This action moulds and helps the Ear Cushions to form an efficient seal against the head around your ear which improves both comfort and hearing protection.

STEP 4 Fitting the Mouth Guard Microphone



The Mouth Guard Microphone (MGM) is intended for use in black noise environments.

An adjustable lanyard strap is provided, that fits over the operator's head, and rests around the neck. This supports the Mouth Guard Microphone assembly at about chest height.

Figure 4.0

a) Connect the MGM plug into the line socket assembly on Headset. (see Figure 4.1)

b) Hold microphone assembly tightly up against lower part of face, so the mouth is enclosed within the Mouth Pad.



Figure 4.1



c) To speak, depress the RED PTS (Push To Speak) button (see Figure C, item 9, page 3) on the top of the housing. When finished speaking, release the PTS button.

Figure 4.2

STEP 5 Checking electronic operation

a) Earphones Check (speakers)

You should hear sound in both Ear Cups from the aircraft comms line. If this is not the case, check the connection to the aircraft and the walk-around cable also ensure the aircraft comms equipment is on and correctly selected.

Caution: Do not set the volume level of the comms equipment too high! See paragraph 2 of **Warnings** on page 2.

b) Microphone Check

Depress the RED, PTS button on top of the Mouth Guard Microphone assembly and confirm your speech is being heard by other personnel also connected to the aircraft comms line. If this is not the case, check the connection to the aircraft and the walk-around cable. Also ensure the aircraft comms equipment is on and correctly selected.

CARE & MAINTENANCE

Do not allow the mouth guard microphone assembly or the headset to contact the ground or suffer hard or sharp impacts.

We recommend that the headset & mouth guard microphone assembly be cleaned regularly, by wiping with a damp sponge containing mild soap and water. Pay special attention to the ear cushions & mouth pad to ensure removal of perspiration and skin oils which can reduce the service life of the cushions. The areas of the headset & mouth guard microphone that come into contact with the wearer's skin should also be regularly disinfected using isopropyl alcohol wipes. **UNDER NO CIRCUMSTANCES SHOULD YOU IMMERSE THE HEADSET IN ANY LIQUID.**

IMPORTANT: This Headset should not be stored in direct sunlight or temperatures above 55 degrees C. as distortion of the ear cushions may occur.

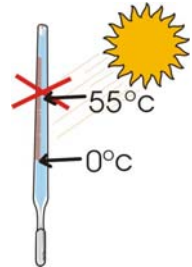

To maintain the noise attenuation properties of the Headset, the ear cushions (see Figure 6.0, item 2) should be replaced every six months and the inner foam assembly (see Figure 6.0 , item 3) every twelve months. Likewise with the MGM mouth pad (see Figure 7.0, item 5) if cleaned regularly should not need replacing for 12 months. The foam cover however (see Figure 7.0, item 6) should be replaced as necessary for hygiene purposes. The MGM urethane inner moulding (see Figure 7.0, item 7) should not need replacing under 12 months. The MGM lanyard strap should be replaced on inspection. More frequent replacement of these items may be required if the Headset is being used under extreme conditions. Inspect the headset regularly for signs of damage or wear.

HEADSET USER REPLACEABLE PARTS – EXPLODED VIEW

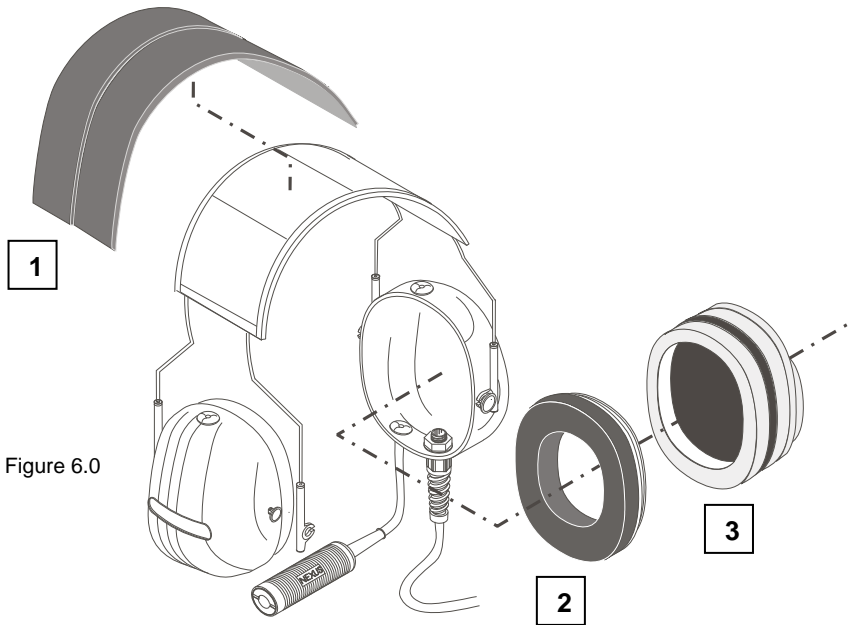

Figure 6.0

USER REPLACEMENT PARTS LIST

Item No:	Order Code	Description
	NSN:	
1	7432300147	Leather Headband Cover (item 1)
2	7432300178-K	Cushion Kit (Pack of 2 x item 2)
	5965-66-151-5602	
3	7432300174-K	Foam & Cushion Kit (Pack of 2 x items 2 & 3)
	5965-66-151-5603	
4	8127743247	Mouth Guard Lanyard Strap Assembly (Pack of 1 x item 4)
5	7432300125	Mouth Guard Microphone PAD (Pack of 1 x item 5)
6	7432300126	Mouth Guard Foam cover (Pack of 4 x item 6)
7	7432300129	Mouth Guard Urethane Inner Moulding (Pack of 1 x item 7)

MGM USER REPLACEABLE PARTS – EXPLODED VIEW

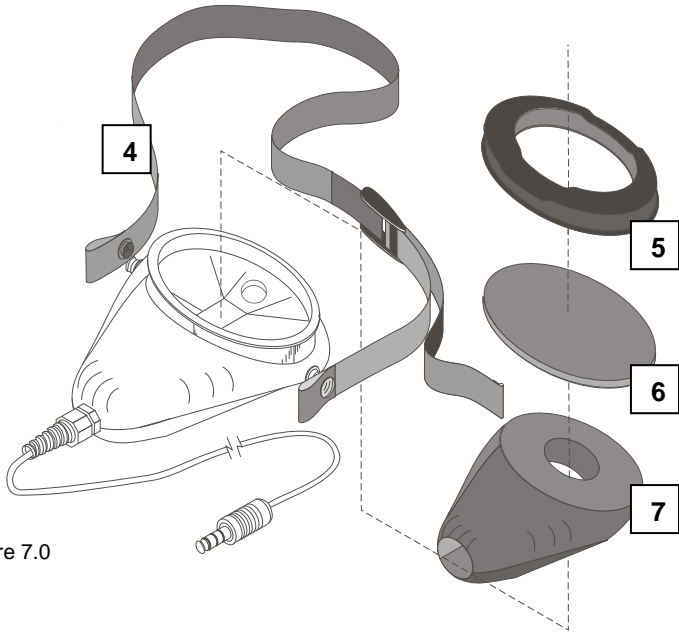

Figure 7.0

USER REPLACEMENT PARTS LIST

Item	Order Code	Description
	NSN:	
Kit	7432300181-K	Mouth Guard Microphone Pad Kit (Pack of 1 x items 5 & 6)
Kit	7432300180-K	MGM Pad & inner Moulding Kit (Pack of 1 x items 5, 6 & 7)

PARTS REPLACEMENT (See items 1 – 7 shown in Figure 6.0 & 7.0)

Each of the parts or kits in the preceding two tables, when ordered, come supplied with their own comprehensive written and pictorially displayed removal and fitting instructions

NOISE EXPOSURE

There is considerable medical research data now available which clearly demonstrates a link between the loss of hearing in humans as a result of exposure to noise. The factors which contribute to this loss of hearing are many and complex, and as the Headset user you should discuss your requirements with suitably qualified professionals to ensure that the headset you have selected is suitable for the type (frequencies) of noise & level of noise you may encounter as well as the period of exposure. The chart below should be read in conjunction with AS/NZ standard 1269.

Noise Exposure Chart

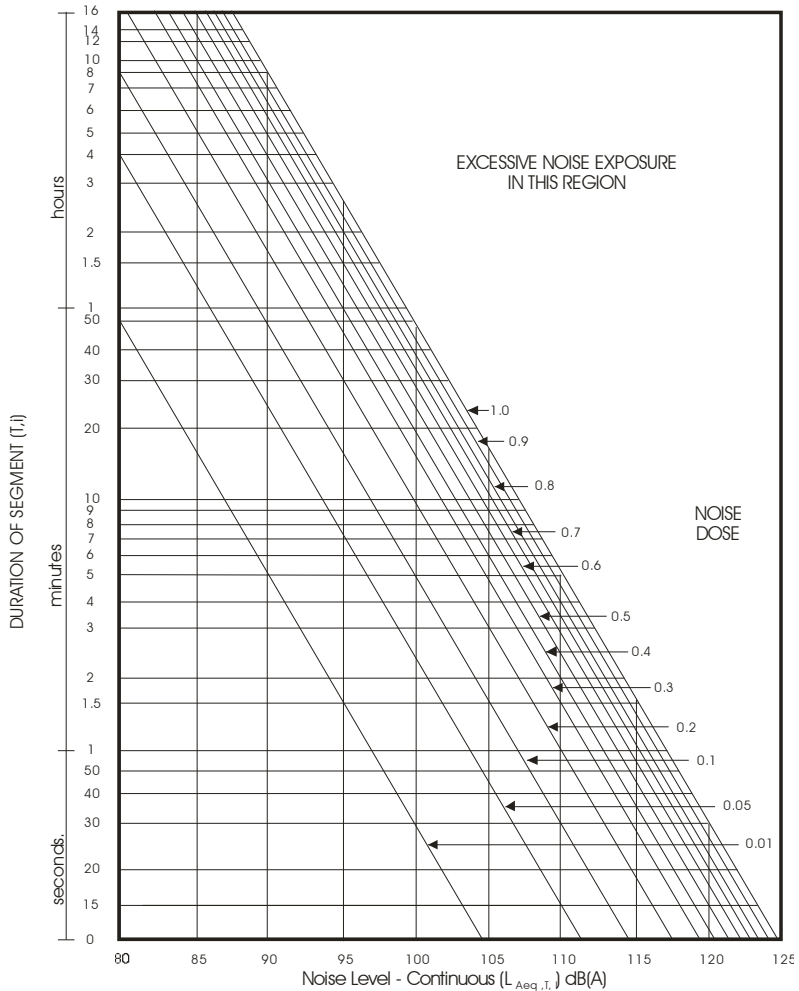

WARRANTY

WARRANTY STATEMENT

Our goods come with guarantees that cannot be excluded under the Australian Consumer Law. You are entitled to a replacement or refund for a major failure and for compensation for any other reasonably foreseeable loss or damage. You are also entitled to have the goods repaired or replaced if the goods fail to be of acceptable quality and the failure does not amount to a major failure.

This warranty is given by Mobile One Australia Pty Limited, ABN 44 001 885 696, Camden Airport Camden NSW 2570 Ph 02 4655 6677

The benefits conferred by this warranty are in addition to all other rights and remedies in respect of the product (or service) which the consumer has under the Australian Consumer Law and any other law in relation to goods and services to which this warranty relates.

Any Mobile One Australia Pty Limited product that fails due to manufacturing defects will be repaired or replaced as follows:

General Aviation & Helicopter Headsets

Three (3) full years from date of purchase

Intercoms, Headsets other than above & Accessories

One (1) full year from date of purchase

Base, Mobile Antennas & Accessories

Five (5) full years from date of purchase

What this warranty does not cover

All headset inner foam assemblies windsocks & ear pads.

Goods that have been modified or altered in any way.

Defects or damage resulting from misuse, accident, impact or neglect.

Goods improperly installed or used contrary to the relevant user guide.

Unauthorised service and or repairs.

How to make a warranty claim

Before the end of the applicable warranty period (see above) return the goods at your expense together with details of the defect, proof of purchase and your contact details.

Subject to accepting your claim, we will return your repaired or replacement product back to you by the best shipping method at our cost.



Mobile One Australia Pty Limited
Camden Airport Camden NSW 2570
PO Box 123 Camden NSW 2570
Ph 02 46556677 Fax 02 46556600
support@mobileone.com.au

M1Warranty 2012 rev1

CONTACT DETAILS

**Mobile One Australia Pty Limited
Electro-Acoustic Service Centre
Camden Airport, Camden NSW.**

**P.O Box 123
Camden
NSW 2570**

**AUSTRALIA
Phone 02 4655 6677
Fax 02 4655 6600**

**INTERNATIONAL
Phone 61 2 4655 6677
Fax 61 2 4655 6600**

www.mobileone.com.au

